

HGC Data Manager

Model HDM303

OVERVIEW

HGC Data Manager (HDM) is a powerful HGC family component, which adds valuable data management function to the analyzer. Model HDM303 is Fieldbus device and is completed by LAS (Link Active Scheduler) which actives as brain in scheduling and controlling Fieldbus communication. Model HDM303 has a Data storage function, which provides analysis data historical facility used as back up system of upper level flow computing. For the fiscal measurements system purpose, 20 PV's from model HGC303 will be converted to the floats data type of Modbus, and transferred to Modbus master device as request. Multi serial port allow user to connect the other Modbus master devices in parallel.



HGC Data Manager unit - Model HDM303

FEATURES

1. **Data storage function:** The latest 18,500 data records are stored in the inside memory of model HDM303. Storage data is 20 PV's of every five minutes of analysis, for 64 days, and calendar for time stamping. Model HDM303 storage includes the average (hourly, daily and monthly) data as well. Available battery back-up for model HDM303 memory is for over 3 years.
2. **Multi serial port:** Two serial port connections are available in one HDM303 for Modbus communication. Users can choose RS 232C, RS 422 or RS485, to follow their type of connection.
3. **Multi stream switching:** Besides auto-calibration and alarm indication relays, model HDM303 has four relay output contacts. These contacts can be used for energizing respective solenoid valves of four different natural gas stream, which are available on the stream board.
4. **Local mounting:** Model HDM303 is a weatherproof device designed to meet NEMA-4X. It conforms CE marking and FM/CSA Non-incendive use in Class I, Division 2, Group (A, B, C, D). Local display indicates one PV and the indicated PV is changeable by infrared touch sensor through the window touch key panel.
5. **Analog output:** Two or three configurable analog outputs are available on the analog board of each model HDM303.

FUNCTIONAL SPECIFICATIONS**Modbus communication**

Protocol	Modbus ASCII Protocol Modbus RTU Protocol (default: Modbus ASCII Protocol)			
Baud rate (bps)	1200, 2400, 4800, 9600, 19200 (default: 9600)			
Port	Model HDM303-22SC: RS-232C, 2 port			
	Model HDM303-24SC: Port1:RS-232C, Port 2: RS485/422 (default: RS485)			
	Model HDM303-44SC: RS485/ RS422, 2 port (default: RS485)			
	Model HDM303-2 <input type="checkbox"/> <input type="checkbox"/> <input type="checkbox"/> : Port1: RS232 *			
	Model HDM303-4 <input type="checkbox"/> <input type="checkbox"/> <input type="checkbox"/> : Port1: RS485/422 (default: RS485)*			
Data length (bit)	7, 8 (default: 7)			
Start bit	1			
Stop bit	1			
Parity	Even, Odd, None, (default: Even)			
Bit structure	LSB: Bit=0, MSB: Bit=7			
Register	Start	End	Type	
	1	...	16 bit integer (Special register for date and time)	
	500	599	Data table	
	3000	4999	16 bit integer	
	5000	5999	32 bit integer	
	7000	8999	32 bit floating	
	10000	28500	Data table	
	30000	30268	Data table	
	50000	50003	Special area	
Modbus slave address (Unit address)	Selectable by S/W setting (default: 1)			
Data transferred from HGC and register configuration (Read only)	OUT	ADD	ADD2	Description
	PV1	7001	3101 & 3102	Sum of C6+ (Sum of hexane or heavier)
	PV2	7002	3103 & 3104	C3H8 (Propane)
	PV3	7003	3105 & 3106	i-C4H10 (i-Butane)
	PV4	7004	3107 & 3108	n-C4H10 (n-Butane)
	PV5	7005	3109 & 3110	neo-C5H12 (neo-Pentane)
	PV6	7006	3111 & 3112	i-C5H12 (i-Pentane)
	PV7	7007	3113 & 3114	n-C5H12 (n-Pentane)
	PV8	7008	3115 & 3116	N2 (Nitrogen)
	PV9	7009	3117 & 3118	CH4 (Methane)
	PV10	7010	3119 & 3120	CO2 (Carbon dioxide)
	PV11	7011	3121 & 3122	C2H6 (Ethane)
	PV12	7033 & 7012	3123 & 3124	Heat value (superior / inferior, ideal / real)
	PV13	7090 & 7013	3125 & 3126	Gas density / Relative density (ideal / real)
	PV14	7037 & 7014	3127 & 3128	Wobbe index (ideal / real)
	PV15	7036 & 7015	3129 & 3130	Compressibility factor
	PV16	7038 & 7016	3131 & 3132	Total of raw concentrations
	PV17	7097 & 7017	3133 & 3134	Oven temperature
	PV18	7098 & 7018	3135 & 3136	Carrier gas pressure
	PV19	7087 & 7019	3137 & 3138	ICV (ideal / real)
	PV20	7035 & 7020	3139 & 3140	Relative density (ideal / real)

Note) *: Please refer to "Model selection" on page 5.

Analog output

Analog output: Two or three PV selectable, 4-20 mA DC (Range is configurable).

Model HDM303-2ASC, HDM303-4ASC, HDM303-AASC

Data storage functions

Analysis data

Register	10000 - 28500	
One record format	Time stamp	Minute, Hour, Day, Month, Year
	Stream number	1 - 4
	Data	PV1 - PV20
Maximum storage data	TOTAL-MAX of 18500 records (for 64 days)	

Average data

Register	30000 - 39999	
Average data	Hourly, Daily, Monthly	
One record format	Time stamp	Minute, Hour, Day, Month, Year
	Stream number	1 - 4
	Average data	PV1 - PV20
	Number of data used for average calculation	
Maximum storage data	Hourly average	30 records per one stream
	Daily average	65 records per one stream
	Monthly average	6 records per one stream

Other functions

Terminator	Built in termination for Fieldbus
Holding register 3058 New data flag (Read and write)	0: Modbus master writes "0" after reading 20 latest PV. 1: New data is available.
Holding register 3047 Error flag (Read only)	0 (0×0000H): Normal condition 1 (0×0001H): RF (response factor) error 2 (0×0002H): Reserve 4 (0×0004H): RAM error 8 (0×0008H): Reserve 16 (0×0010H): CPU communication error 32 (0×0020H): Timer error 64 (0×0040H): Battery exchange status (0 = Battery normal, 1 = Battery change needed) 128 (0×0080H): HGC no response 256 (0×0100H): HGC overhaul time 512 (0×0200H): Chromatogram peak height over the measurement range 1024 (0×0400H): Carrier gas pressure out of control 2048 (0×0800H): Oven temperature error 4096 (0×1000H): Chromatogram baseline error 8192 (0×2000H): Carrier gas pressure error 16384 (0×4000H): Oven temperature extremely high 32768 (0×8000H): HGC data bad
Holding register 3059 Cal /Analysis flag (Read only)	1: Analyzing 0: Calibrating
Holding register 3000 error out- put setting flag For all bits: 0 = error OFF, 1 = error ON (Read and write) (default: 1111 1111 1111 0101B)	0 bit: RF (response factor) error 1st bit: Reserve 2nd bit: RAM error 3rd bit: Reserve 4th bit: CPU communication error 5th bit: Timer error 6th bit: Battery exchange status (0 = Battery normal, 1 = Battery change needed) 7th bit: HGC no response 8th bit: HGC overhaul time 9th bit: Chromatogram peak height over the measurement range 10th bit: Carrier gas pressure out of control 11th bit: Oven temperature error 12th bit: Chromatogram baseline error 13th bit: Carrier gas pressure error 14th bit: Oven temperature extremely high 15th bit: HGC data bad

(Continued)

Other functions (continued from previous page):

Holding register 3034 current stream number (Read only)	1, 2, 3, 4 (default:1)
Holding register 3061 last stream number (Read only)	1, 2, 3, 4 (default: 1)
Holding register between 3036 and 3040 current time (Read only)	3036: Month, 3037: Day, 3038: Year, 3039: Hour, and 3040: Minute
Holding register between 3041 and 3045 start time of analysis (Read only)	3041: Month, 3042: Day, 3043: Year, 3044: Hour, and 3045: Minute
Holding register 3001 C6+ Calculation Method	108: C6+ rate (C6=0.47466, C7=0.3534, C8=0.17194) Default 109: C6+ rate (C6=0.5, C7=0.5, C8=0.0) 110: C6+ rate (C6=0.5, C7=0.25, C8=0.25) 111: C6+ rate (C6=0.57143, C7=0.28572, C8=0.14285)
Holding register 3002 (Read and Write)	Component Index_1: 102 (default)
Holding register 3003 (Read and Write)	Component Index_2: 103 (default)
Holding register 3004 (Read and Write)	Component Index_3: 104 (default)
Holding register 3005 (Read and Write)	Component Index_4: 107 (default)
Holding register 3006 (Read and Write)	Component Index_5: 105 (default)
Holding register 3007 (Read and Write)	Component Index_6: 106 (default)
Holding register 3008 (Read and Write)	Component Index_7: 114 (default)
Holding register 3009 (Read and Write)	Component Index_8: 100 (default)
Holding register 3010 (Read and Write)	Component Index_9: 117 (default)
Holding register 3011 (Read and Write)	Component Index_10: 117 (default)
Holding register 3012 (Read and Write)	Component Index_11: 255 (default)
Holding register 3013 (Read and Write)	Component Index_12: 255 (default)
Holding register 3014 (Read and Write)	Component Index_13: 255 (default)
Holding register 3015 (Read and Write)	Component Index_14: 255 (default)
Holding register 3016 (Read and Write)	Component Index_15: 255 (default)

Fieldbus

Conforms to FOUNDATION™ fieldbus specification, ISA S50.02-1992 and IEC 1158-2
Fieldbus address default =16 (10H), PD Tag = HDM303

PHYSICAL SPECIFICATIONS:**Instrument construction:**

Dimensions:	W: 164 mm × D: 128 mm × H: 231 mm	
Weight:	3 kg	
Materials	Case	Aluminum alloy
	Window	Tempered glass (5 mm thick)
Mounting	Wall mounting, 2-inch pipe mounting	
Painting color	Light beige (Munsell 4Y7.2/1.3) acrylic resin	
CE Marking:	Electromagnetic compatibility (89/336/EEC, 92/31/EEC, 93/68/EEC)	

INSTALLATION**Instrument environment**

Environmental classification:	Local location
Ambient temperature:	-10 to 50°C -20 to 70°C (storage and transportation)
Ambient humidity range	0 - 95% RH

Power supply

Power supply	24 V DC ± 10%
Power consumption	Min. 5 VA (external solenoid valve power consumption is not included)

Relay

Auto calibration relay:	Normal open (default) 24 V DC, 1A Open collector
Status relay (Alarm output):	Normal close (default) 24 V DC, 1A Open collector
Multi-stream relay	Normal open (default) 24 V DC, 1A Open collector (Two or four contacts selectable) Model: HDM303-2DSC, HDM303-2DDD, HDM303-4DSC, HDM303-4DDD

MODEL SELECTION**HGC Data Manager**

HDM303 - I

Basic model number		Selection	
	HDM303-		
I	Communication & contact	RS232 / RS232 / STATUS / Calibration	22SC
		RS232 / RS485 / STATUS / Calibration	24SC
		RS485 / RS485 / STATUS / Calibration	44SC
		RS232 / 2-Stream / STATUS / Calibration	2DSC
		RS232 / 4-Stream	2DDD
		RS485 / 2-Stream / STATUS / Calibration	4DSC
		RS485 / 4-Stream	4DDD
		RS232 / 2-Analog / STATUS/Calibration	2ASC
		RS485 / 2-Analog / STATUS / Calibration	4ASC
	3-Analog / STATUS / Calibration	AASC	

DIMENSIONS

[Unit: mm]

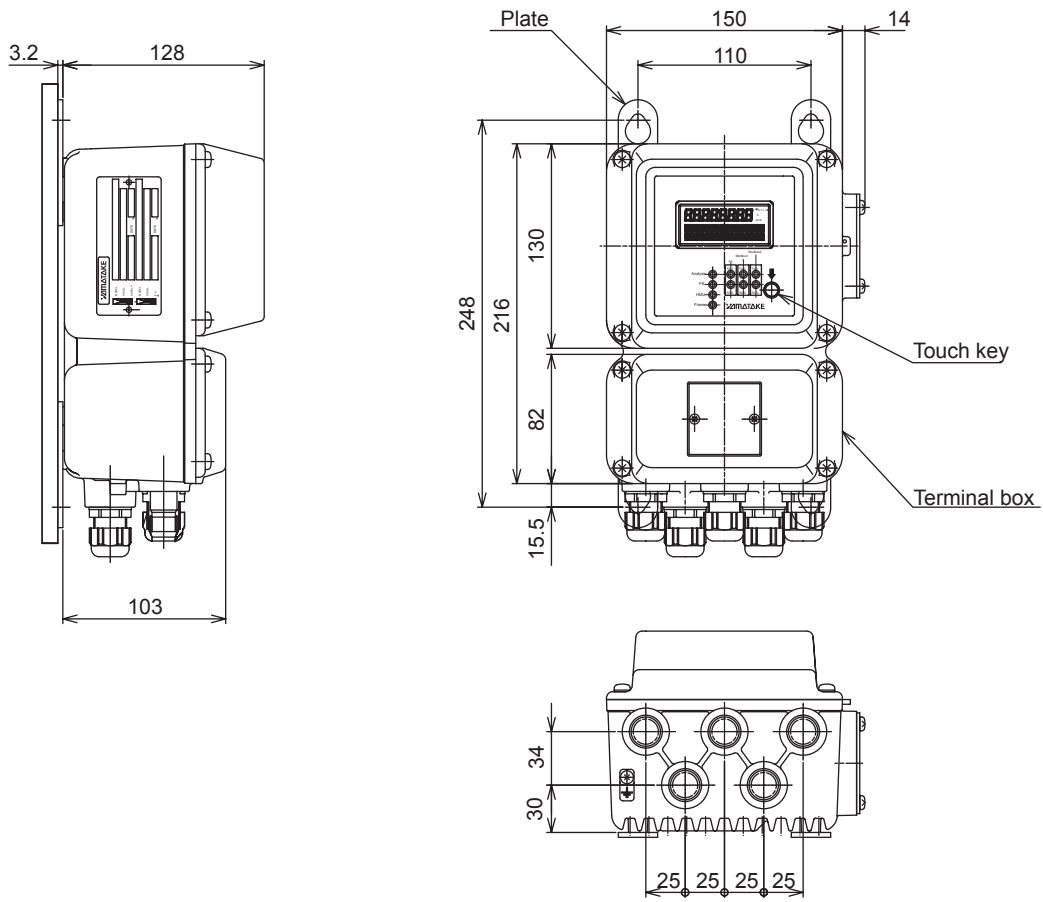

[Unit: mm]

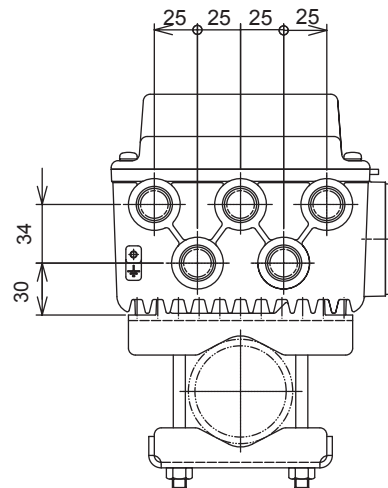
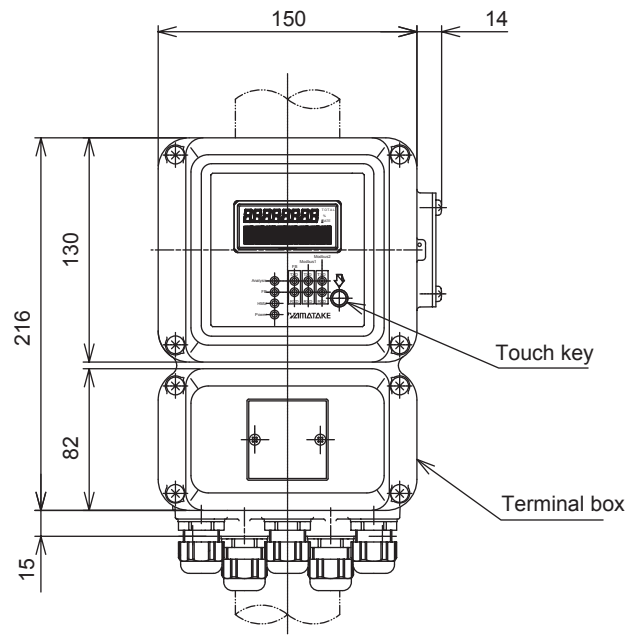
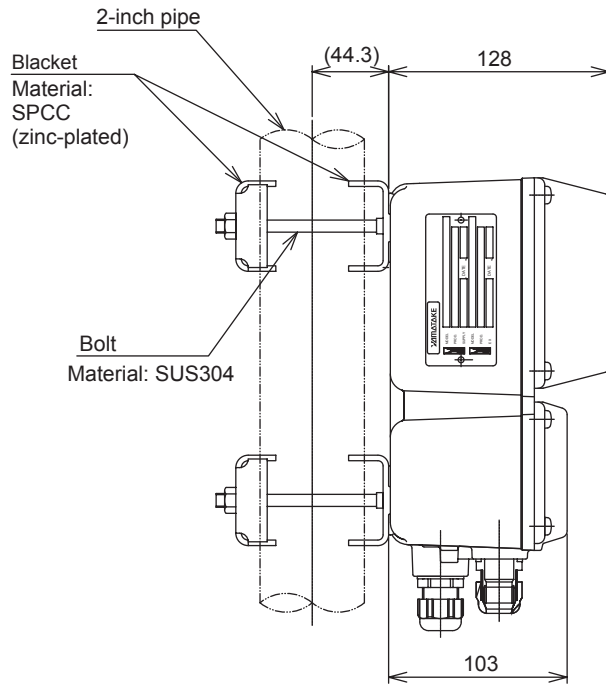

[Unit: mm]

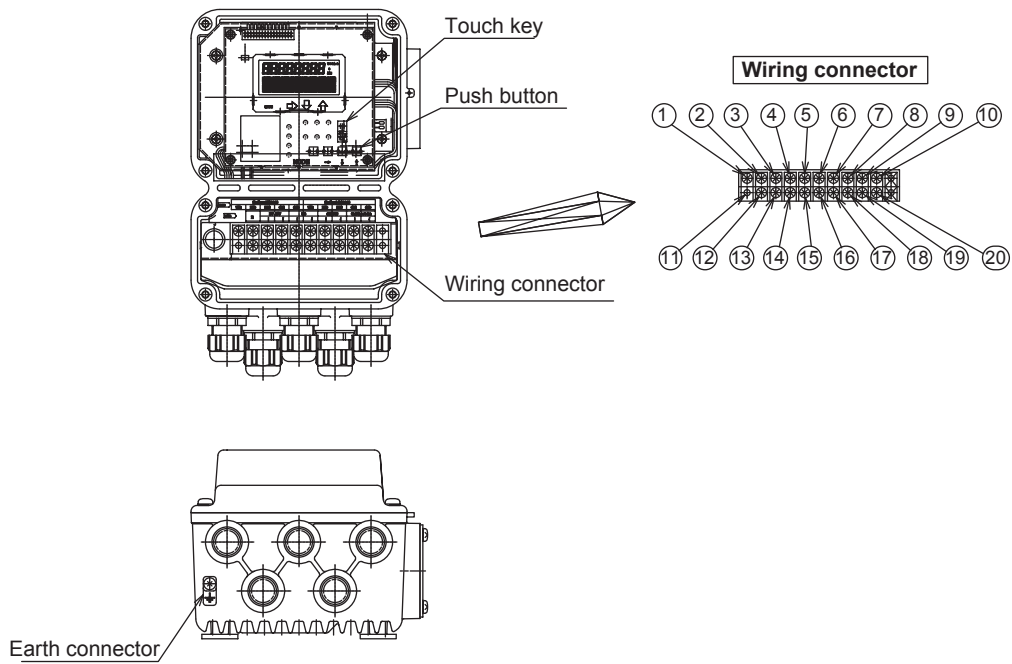

Yamatake Corporation

Totate international Building
2-12-19 Shibuya
Shibuya-ku, Tokyo 150-8316
Japan

Tel : 81-3-3486-2310
Fax : 81-3-3486-2593

YAMATAKE
Savemation

Saving through Automation